

# Electric Wrap Spring Clutches

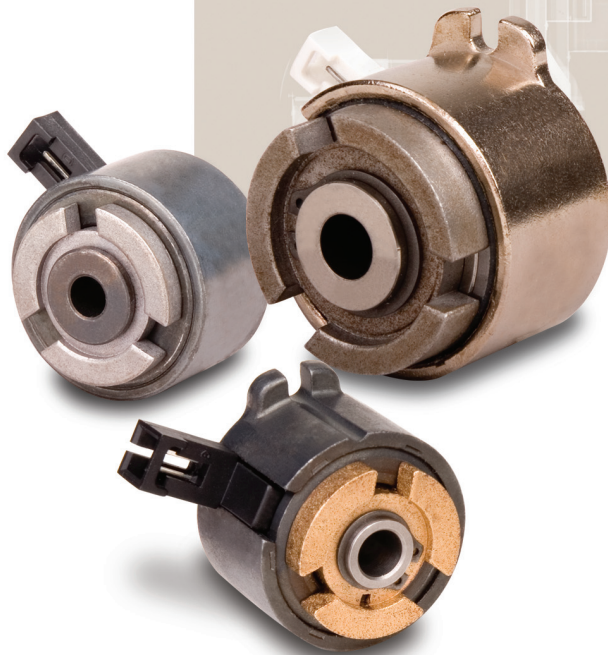

For Paper and Envelope  
Feed Applications



## How To Select

Wrap spring clutches will engage consistently and accelerate to full speed almost instantaneously (2–3 milliseconds). To calculate your total load, use the following formulas:

### Clutch Torque

$$T_c = \frac{WR^2 \times N}{C \times t} + T_F$$

Where:

**T<sub>c</sub>** = Torque required from wrap spring clutch

**WR<sup>2</sup>** = Total inertia reflected to the clutch, lb.-in.<sup>2</sup>

**N** = Shaft speed at clutch, RPM

**C** = Constant, use 3696 for English units and 9.55 for metric units

**t** = Acceleration time, seconds, use .003

**T<sub>F</sub>** = Frictional torque to overcome motion (other than inertia), lb.-in. (N-m)

To calculate the inertia for a cylinder, the formula is:

$$WR^2 = \frac{\pi}{32} \times D^4 \times L \times \rho$$

Where:

**WR<sup>2</sup>** = Inertia, lb.-in.<sup>2</sup> (kg-m<sup>2</sup>)

**D** = Diameter – inches (meters)

**L** = Length – inches (meters)

**ρ** = Density – lb./in.<sup>3</sup> (kg/m<sup>3</sup>)

Approximate values for ρ are:

Steel = .284 (7860)

Aluminum = .098 (2700)

Plastic = .047 (1300)

Rubber = .047 (1300)

ESC clutches are rated by static torque. If your required torque exceeds the clutch rating, consult Warner Electric for assistance.

### Selection Considerations

The clutch size is determined mostly from the clutch torque required. The inertia to be accelerated, the speed, load torque, duty cycle, and life requirements are all considerations in clutch sizing. Other conditions to be considered are ambient temperatures, humidity, dust, and contaminants which may affect the clutch performance. For these reasons, clutch performance should be evaluated under actual application conditions.

### Maintenance

ESC clutches are maintenance-free. The clutch should be kept free of grease and oil for proper operation. The clutch is specially lubricated at the factory and should not be lubricated once installed.

### Speed vs. Time

Response time for ESC clutches

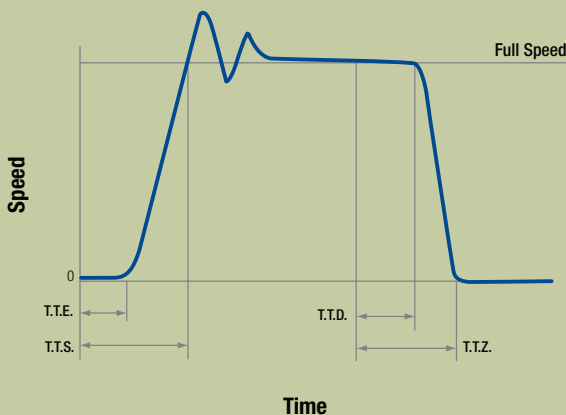

Where:

**T.T.E. = Time To Engage**

(collar engagement + spring wrap time, which varies with input speed)

**T.T.S. = Time To Speed**

(T.T.E. + acceleration time)

**T.T.D. = Time To Disengage**

(flux decay time + spring unwrap time)

**T.T.Z. = Time To Zero**

(T.T.D. + deceleration time, which varies with your system drag and inertia loads)

### Input Rotation

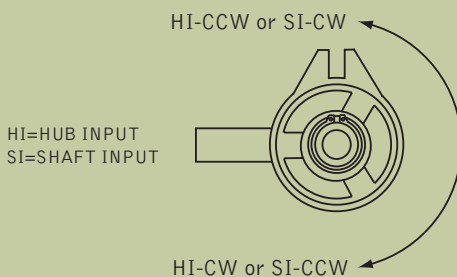

Drive direction is viewed from free hub end.

## Principle of Operation – Generating the Clutch Torque

### De-Energized

ESC clutches consist of five basic parts for operation: free hub, shaft hub, control ring, spring, and housing with coil. The inside diameter of the spring is slightly larger than the outside diameter of the hubs. One end of the spring is fastened to the free hub, the other to the control ring. The control ring, free hub, and spring rotate together. The shaft hub remains stationary when the coil is de-energized. The housing is held stationary by a fixed pin in the anti-rotation tab and pilots on the shaft hub.

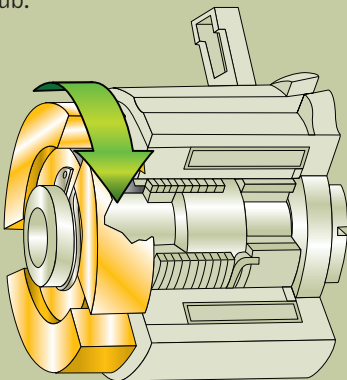

### Energized

When the coil is energized, the control ring is magnetically pulled against the shoulder of the housing, causing the control ring to become fixed to the shaft hub. The spring is wrapped down, which couples the free hub to the shaft hub. The torque is now transmitted through the spring. The magnetic force keeps the spring wrapped for full torque output.

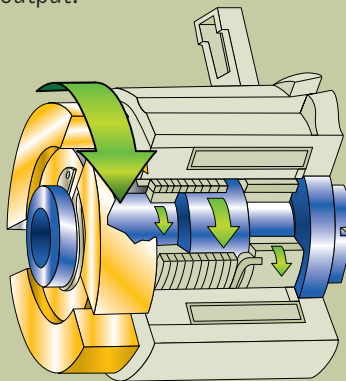

## Design Considerations

All ESC clutches are unidirectional as opposed to our electromagnetic friction clutches, which operate bi-directionally. They provide positive engagement, with no slip, almost instantaneously. The time to engage the ESC clutch is directly related to the input speed. The slower your input speed the longer it takes to reach full speed. The time to disengage depends on voltage transients and your switching circuit. Your circuit will affect the disengagement time of the clutch. The ESC features a three-lug drive hub for easy mating to gears, pulleys, or sprockets. When ordering an ESC clutch you will need to know:

- Input direction – CW or CCW
- Hub or shaft input
- Voltage
- Shaft diameter

## Applications

### Paper and Envelope Feeders

These applications require feeding a sheet of paper or envelope in a specified time period. The clutch must reach full speed consistently, and the time to speed variation cannot exceed a specified window of time.

ESC clutches provide consistent acceleration and time to speed for accurate feeding. These compact clutches are ready to mount and are maintenance-free. They feature high torque capability and are easily connected via an integral AMP MTE connector.

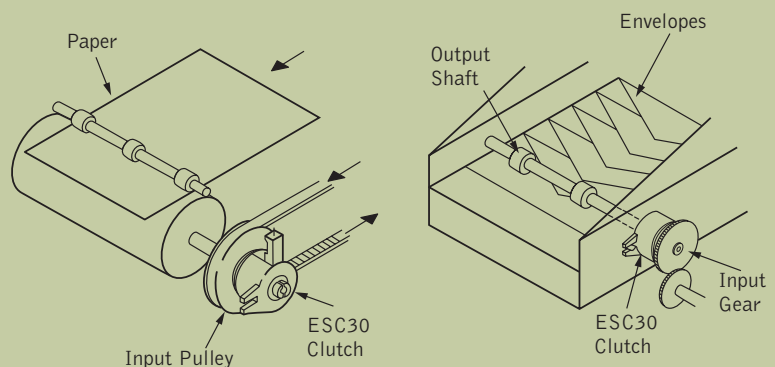

Paper Feeder

Envelope Feeder

## Specifications

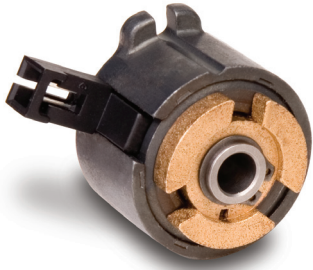

	ESC30	ESC30LL
Torque Rating	25 in./lbs.	25 in./lbs.
Direction of Rotation	CW or CCW	CW or CCW
Bore Sizes	1/4 in. (.250) 6 mm	1/4 in. (.250) 6 mm
Shaft Mounting	Cross pin 3/32 or 2.5 mm	Cross pin 3/32 or 2.5 mm
Electrical Connection	Molded connector on 8 in. lead wires	Molded connector on 8 in. lead wires
Rated Bearing Revolutions	25 million revolutions	60 million revolutions
Maximum Speed	1400 rpm	1400 rpm

## Dimensions

### ESC30 and ESC30LL

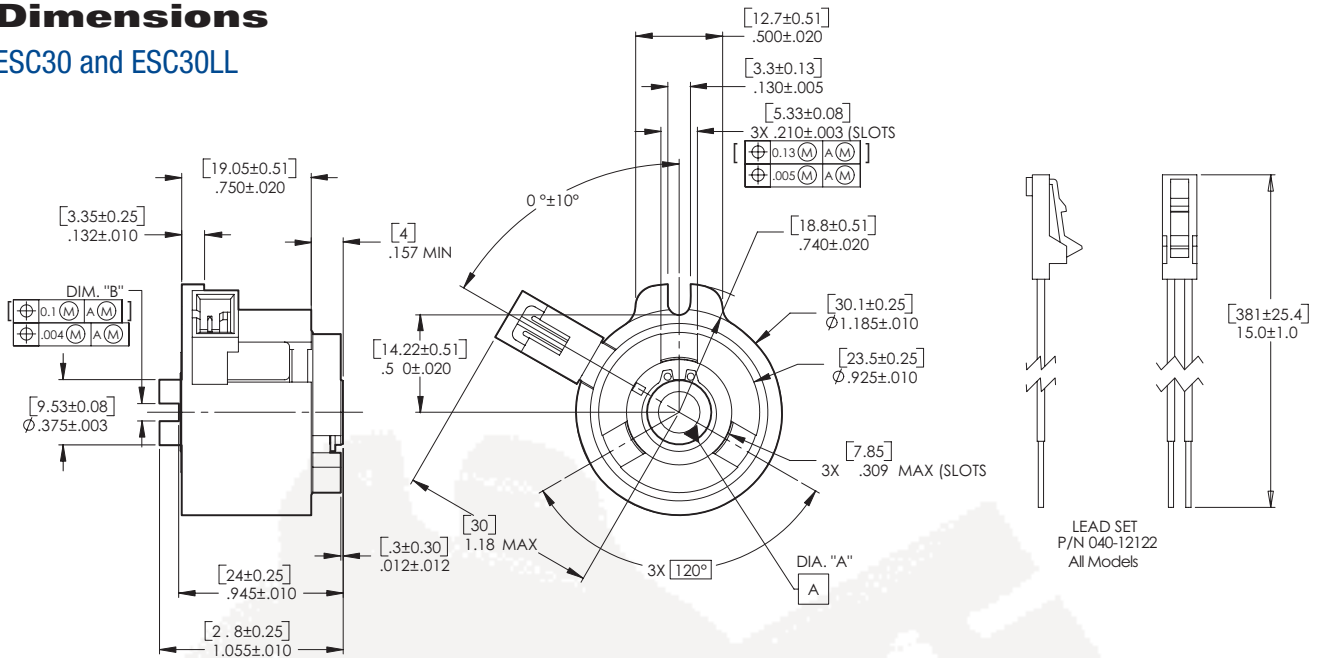

Part Number	Description	Voltage	Bore
102-10-252	ESC30 HI-CW/SI-CCW 24 vdc 1/4 bore connector	24 vdc	1/4
102-10-158	ESC30 HI-CW/SI-CCW 24 vdc 6 mm connector	24 vdc	6 mm
102-20-157	ESC30 HI-CCW/SI-CW 24 vdc 1/4 bore connector	24 vdc	1/4
102-20-158	ESC30 HI-CCW/SI-CW 24 vdc 6 mm connector	24 vdc	6 mm
102-10-902	ESC30LL HI-CW/SI-CCW 24 vdc 1/4 bore connector	24 vdc	1/4
102-10-905	ESC30LL HI-CW/SI-CCW 24 vdc 6 mm connector	24 vdc	6 mm
102-20-902	ESC30LL HI-CCW/SI-CW 24 vdc 1/4 bore connector	24 vdc	1/4
102-20-905	ESC30LL HI-CCW/SI-CW 24 vdc 6 mm connector	24 vdc	6 mm
102-10-180	ESC33LL HI-CW/SI-CCW 24 vdc 1/4 bore connector	24 vdc	1/4
102-10-182	ESC33LL HI-CW/SI-CCW 24 vdc 6 mm connector	24 vdc	6 mm
102-10-183	ESC33LL HI-CW/SI-CCW 24 vdc 8 mm connector	24 vdc	8 mm
102-20-184	ESC33LL HI-CCW/SI-CW 24 vdc 1/4 bore connector	24 vdc	1/4
102-20-186	ESC33LL HI-CCW/SI-CW 24 vdc 6 mm connector	24 vdc	6 mm
102-20-187	ESC33LL HI-CCW/SI-CW 24 vdc 8 mm connector	24 vdc	8 mm
104-10-905	ESC75LL HI-CW/SI-CCW 24 vdc 1/2 bore leads	24 vdc	1/2
104-10-904	ESC75LL HI-CW/SI-CCW 24 vdc 3/8 bore leads	24 vdc	3/8
104-10-906	ESC75LL HI-CW/SI-CCW 24 vdc 5/8 bore leads	24 vdc	5/8
104-20-905	ESC75LL HI-CCW/SI-CW 24 vdc 1/2 bore leads	24 vdc	1/2
104-20-904	ESC75LL HI-CCW/SI-CW 24 vdc 3/8 bore leads	24 vdc	3/8
104-20-906	ESC75LL HI-CCW/SI-CW 24 vdc 5/8 bore leads	24 vdc	5/8

## Specifications

	ESC33LL	ESC75LL
Torque Rating	30 in./lbs.	75 in./lbs.
Direction of Rotation	CW or CCW	CW or CCW
Bore Sizes	1/4 in. (.250) 5/16 in. (.3125) 6 mm 8 mm	3/8 in. (.375) 1/2 in. (.500) 5/8 in. (.625) 10 mm, 12 mm, 15 mm
Shaft Mounting	Cross pin 3/32 or 2.5 mm	Cross pin 1/8 or 3 mm
Electrical Connection	Molded connector	Molded connector
Rated Bearing Revolutions	80 million revolutions	100 million revolutions
Maximum Speed	1400 rpm	1400 rpm

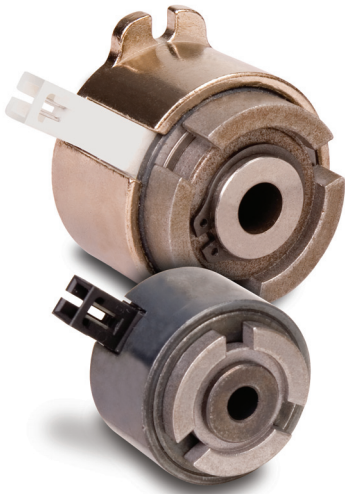

## Dimensions

### ESC33LL

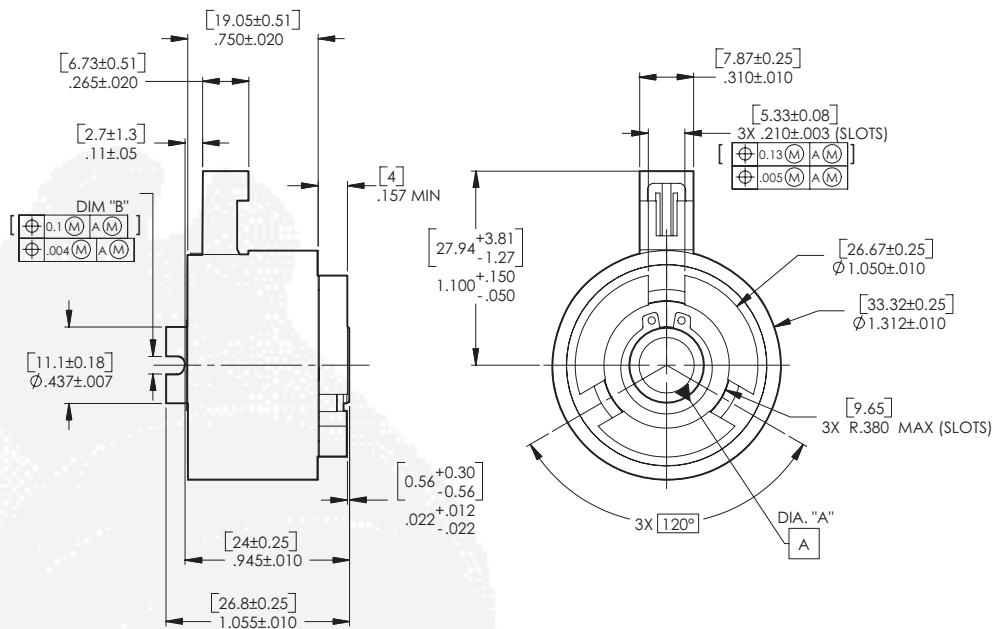

### ESC75LL

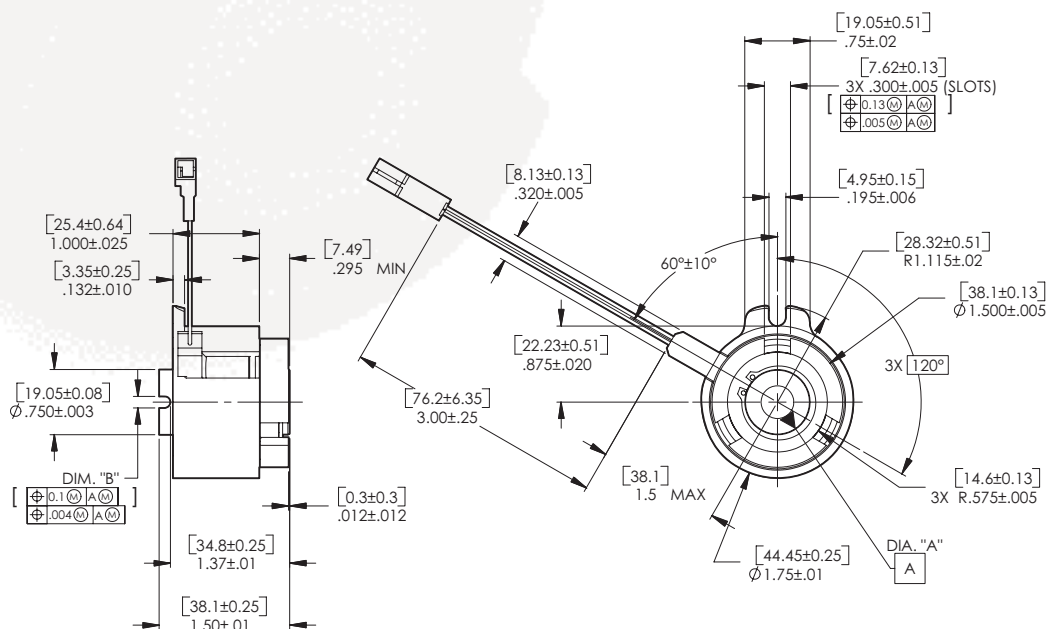

# Altra Industrial Motion

## **Warner Electric**

*Electromagnetic Clutches and Brakes - USA*

South Beloit, IL 61080  
815-389-3771

For application assistance:  
1-800-825-9050

*Electromagnetic Clutches and Brakes - Europe*

St Barthelemy d'Anjou, France  
+33 (0)2 41 21 24 24

For sales office:  
+33 (0)2 41 21 24 76

*Precision Electric Coils and Electromagnetic Clutches and Brakes - USA*

Columbia City, IN 46725  
260-244-6183

## **Inertia Dynamics**

*Spring Set Brakes; Power On and Wrap Spring Clutch/Brakes*

Torrington, CT 06790  
860-482-4444

## **Matrix International**

*Electromagnetic Clutches and Brakes; Pressure Operated Clutches and Brakes*

Brechin, Scotland  
+44 (0) 1356 602000

## **Warner Linear**

*Linear Actuators and Guideways - USA*

Belvidere, IL 61008  
815-547-1106

For application assistance:  
1-800-825-9050

## **Boston Gear**

*Enclosed and Open Gearing, Electrical and Mechanical P.T. Components, Precision Gearheads, Precision Couplings*

Quincy, MA 02171  
617-328-3300

For customer service:  
1-888-999-9860

For application assistance:  
1-800-816-5608

## **Huco Dynatork**

*Precision Couplings and Air Motors*

Hertford, England  
+44 (0) 1992 501900

## **Formsprag Clutch**

*Overrunning Clutches and Holdbacks*

Warren, MI 48089  
586-758-5000

For application assistance:  
1-800-927-3262

## **Marland Clutch**

*Roller Ramp and Sprag Type Overrunning Clutches and Backstops*

Burr Ridge, IL 60527  
630-455-1752

## **Stieber Clutch**

*Overrunning Clutches and Holdbacks*

Heidelberg, Germany  
+49 (0)6221 30 47 0

## **Wichita Clutch and Industrial Clutch**

*Pneumatic and Oil Immersed Clutches and Brakes - USA*

Wichita Falls, TX 76302  
940-723-3400

*Pneumatic Clutches and Brakes - Europe*

Bedford, England  
+44 (0)1234 350311

## **Twiflex Limited**

*Caliper Brakes and Thrusters*

Twickenham, England  
+44 (0) 20 8894 1161

## **Ameridrives Couplings**

*Gear Couplings, Mill Spindles, Universal Joints*

Erie, PA 16512  
814-480-5000

## **Bibby Transmissions**

*Disc, Gear, Grid Couplings, Overload Clutches*

Dewsbury, England  
+44 (0) 1924 460801

## **Nuttall Gear and Delroyd Worm Gear**

*Worm Gear and Helical Speed Reducers*

Niagara Falls, NY 14302  
716-298-4100

## **Saftek Friction**

*Non-asbestos Brake and Clutch Materials*

Telford, England  
+44 (0) 1952 581122

## **Altra Industrial Motion - Asia Pacific and Africa**

China	852 2615 9313
Taiwan	886 2 2577 8156
Singapore	65 487 4464
Thailand	66 2 322 5527
Australia	612 9894 0133
S. Africa	27 11 918 4270



**The Power of Experience**



MEX (55) 53 63 23 31 MTY (81) 83 54 10 18  
QRO (442) 1 95 72 60 ventas@industrialmagza.com

449 Gardner Street  
South Beloit, IL 61080

[www.warnerelectric.com](http://www.warnerelectric.com)

P-1644-WE 2/07 Printed in USA